

# **CASE IH 500T CLOSER** **FOR CIH 500T AIR DRILLS** **INSTALLATION INSTRUCTIONS**

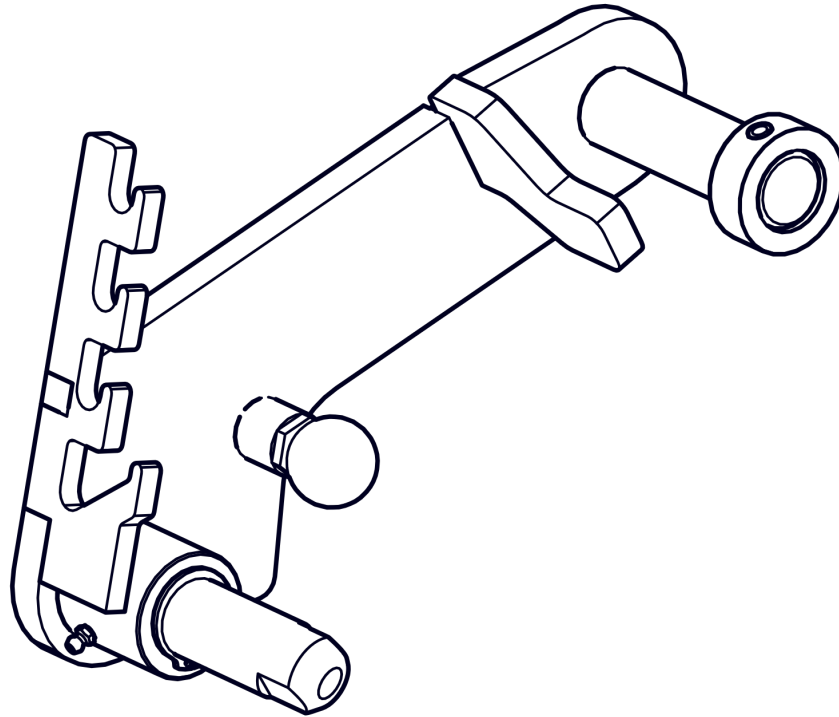

## **Martin Planter Attachments**

**Martin Industries LLC**

206 Elk Fork Road

Elkton, KY 42220

Telephone: 270-265-5817

E-Mail: [martin@martintill.com](mailto:martin@martintill.com)

[www.martintill.com](http://www.martintill.com)



## **INSTALLING CIH 500T CLOSING ARM**

- 1) Remove the factory Closing Wheel from the CIH 500T Arm. Keep hardware and spacers to be used with Martin Till assembly. (12mm and 25mm Spacers)
- 2) With the Collar and Roll Pin off, slide top shaft into the row unit in place of the factory arm and install collar and roll pin to secure.
- 3) Using the factory hardware (5/8-11 Bolt, 12 mm Spacer and 25 mm Spacer), install factory wheel based on your planting depth as shown below.

### **1/2" PLANTING DEPTH**

Use 12mm Spacer between the Axle surface and the Factory Wheel and 25mm Spacer under the head of the Wheel Bolt

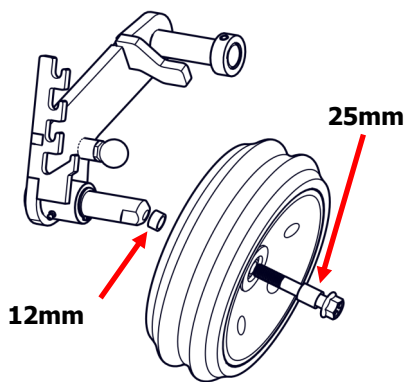

### **1" PLANTING DEPTH**

Use 25mm Spacer between the Axle surface and the Factory Wheel and 12mm Spacer under the head of the

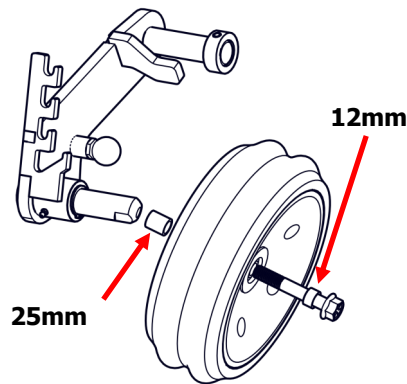

### **1 1/2" PLANTING DEPTH**

Use 12mm and 25mm Spacer between the Axle surface and the Factory Wheel.

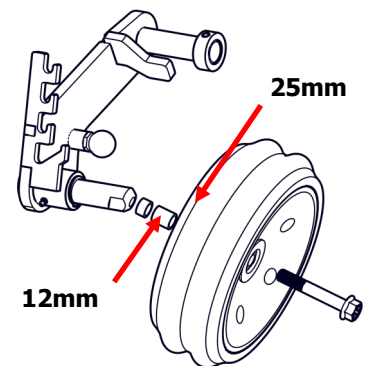

## **WHEEL ANGLE ADJUSTMENT**

To adjust Toe in Angle, pull the round knob of the plunger towards the wheel and move the Lever Arm to desired hole. Release Lever out of lock position to set angle. Second hole from bottom of arm sets the toe-in angle at neutral position. See below for angle adjustments for each hole.

### **LEVER (800524) AT NEUTRAL SETTING**

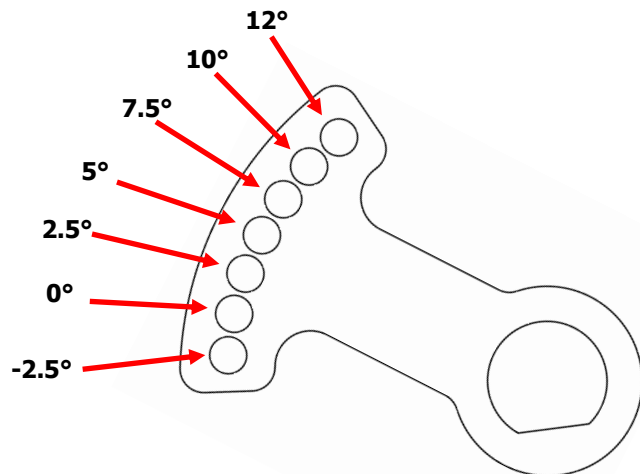
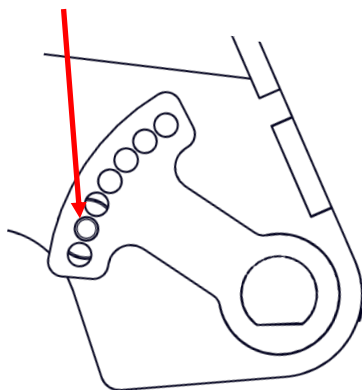

**The most trusted name in no-till  
Established 1991**